

## How to operate Titan Camper Jacks

### SAFETY FIRST!

1. Never allow the camper jack to be occupied while it is being loaded or unloaded.
2. Never raise the rear of the camper higher than the front of the camper.
3. Always check to be sure that all tie-down devices and electrical devices are disconnected from the vehicle body.
4. Do not load camper on a windy day. The amount of wind that is dangerous depends on your exposure, weight of the camper, etc.
5. Only store your camper on level ground.

After adjusting jack to vertical position, insert bottom stem into socket of tripod. With the crank handle carefully and firmly tighten the mounting bolts.

Lower all jacks (winding downward with crank handle) until stems bottom completely into sockets of tripods. **ALWAYS BE SURE THAT JACK STEM IS FULLY BOTTOMED INTO TRIPOD.**

- A. Be sure the tripod legs are fully extended.
- B. Be sure that jack screw has bottomed into the tripod.
- C. Be sure that the tripod chains are straight and not twisted.
- D. Be sure that the tripod legs are fully extended and equidistant to each other.

**THIS MUST BE DONE BEFORE ANY ATTEMPT IS MADE TO RAISE THE CAMPER.** Never place blocks or anything else under jack or tripod.

Always be sure that the front of the camper is never lower than the rear.

#### 3 Jack System

Raise each jack about four inches at a time until camper is completely free of truck. After removal of truck, lower jacks and camper to the lowest possible position.

#### 4 Jack System

Raise one side (both jacks) four inches maximum at a time; then the opposite side and until camper is completely free of truck. After removal of truck, lower jacks and camper into lowest possible position.

Be very careful when lowering jacks. Each jack has what is known as built-in stops. Never exert pressure against these stops because there is danger of damage to the gears.

When choosing a location for unloading the camper select the firmest ground available even though the large area pads of the TITAN's tripod minimize soft, "sink-in" problems.

#### LIMITED WARRANTY

The TITAN Tripod Mechanical Jack is warranted against manufacturing defects and workmanship for one (1) year from the date of purchase. Within this period, RIECO-TITAN PRODUCTS, INC. will at its option, repair or replace the product or any part thereof without charge for parts and labor. To exercise the warranty, the product and the original invoice must be returned to RIECO-TITAN PRODUCTS, INC., freight prepaid and insured.

This warranty does not apply in the following cases: improper installation, misuse, failure to follow installation and operating instructions, alterations, abuse, tampering or accident.

All statements, technical information and recommendations contained herein are based on tests we believe to be reliable, but the accuracy or completeness thereof is not guaranteed, and the following is made in lieu of all warranties expressed or implied. Sellers and manufacturer's only obligation shall be to replace such quantity of the product proved to be defective in accordance with published Warranty Policy. Neither seller nor manufacturer shall be liable for any injury, loss or damage, direct or consequential arising out of the use or the inability to use the product. Before using, user shall determine the stability of the product for his intended use, and user assumes all risk and liability whatsoever in connection therewith.

Except as provided herein, RIECO-TITAN PRODUCTS, INC., makes no express warranties and any implied warrant of merchantability of fitness for a particular purpose is limited to the duration of the written limited warranties set forth herein.

There will be charges rendered on repairs to the product made after the expiration of the aforesaid one year Warranty Period.

RIECO-TITAN PRODUCTS, INC. 965 LAMBRECHT RD, FRANKFORT, IL 60423 - (815)464-7400 FAX (815)469-4705

[www.riecotitan.com](http://www.riecotitan.com)



## Heavy Duty Tripod Camper Jack

2000 lb.  
capacity per jack

### Instructions for Installation, Operation and Maintenance

The superior design and construction of TITAN CAMPER JACKS give them tremendous load bearing strength with simple and easy maintenance. Before the jacks are used be sure you thoroughly understand just how they are to be installed and operated.

Each TITAN CAMPER JACK is made up of the following parts:

| PARTS  | NUMBER |
|--|--------|
| Mounting Brackets . . . . .  | 3      |
| Jack Screw Assemblies . . . . .  | 3      |
| 5/8" - 11 x 1 1/4 Lg. Hex Head<br>Machine Screws with 5/8" - 11 Hex Nuts . . . . . | 6      |
| Tripod Assemblies . . . . .  | 3      |
| Carrier Rings . . . . .  | 3      |
| Crank Handles . . . . .  | 2      |

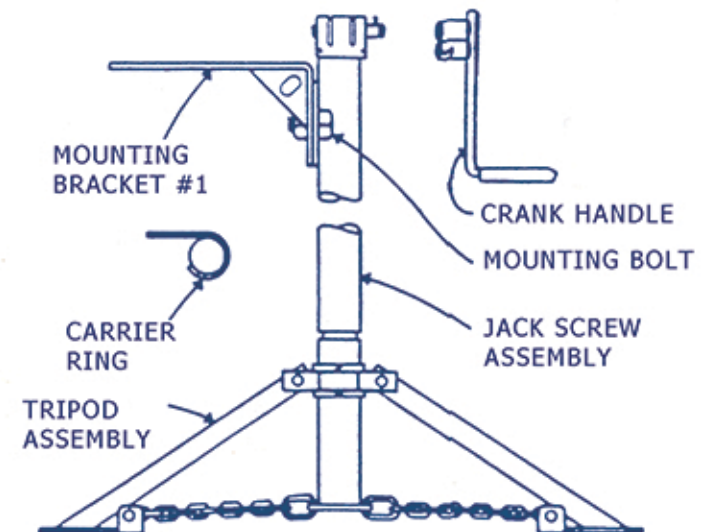

## INSTALLATION

It is very important to give consideration to the camper's weight distribution when the mounting brackets are installed.

- A. The heaviest side of the camper should be supported by two jacks and the third should be placed at the balance point on the opposite side. Keep the mounting brackets which are on the heaviest side as far apart as possible. (See Fig. A on opposite page.)
- B. This is important. The mounting bracket's face (side which bolts to jack) should extend only far enough beyond the camper's side to permit clearance between the camper and the jack. (See Fig. B on opposite page.)
- C. Unfortunately, camper sidewalls and floors vary throughout the industry. This makes it imperative to reinforce the jacks' mounting positions to prevent damage which might result from inadequate structural strength. (See Fig. B on opposite page.)
- D. Having carried out the suggestions mentioned above, use lag screws and/or bolts to fasten the mounting brackets to the camper.
- E. The final procedure - locating the carrier brackets on the camper - is quite simple. Fasten each jack to the mounting bracket. One bolt should be used as a pivot in raising the jack (with stem withdrawn) until it is parallel to the camper body. (See Fig. A on opposite page.) Make a mark on the camper where the jack ends. Position the carrier brackets 1" from this mark. Fasten bracket to camper using bolts and/or lag screws.
- F. Do not use camper jacks for storage of camper. Camper should be lowered and stored on a sturdy base.
- G. In order to maintain the long life and zinc-plated finish of the jacks, it is recommended that the jacks be stored indoors when not used for long periods of time.

| MODEL   | MAXIMUM CAMPER WEIGHT |      |      |      |
|---------|-----------------------|------|------|------|
|         | 1500                  | 2300 | 2750 | 4000 |
| 3-1000# | X                     |      |      |      |
| 4-1000# | X                     | X    |      |      |
| 3-2000# | X                     | X    | X    |      |
| 4-2000# | X                     | X    | X    | X    |

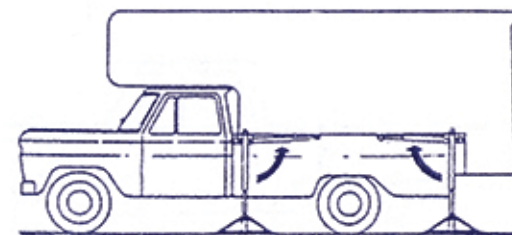
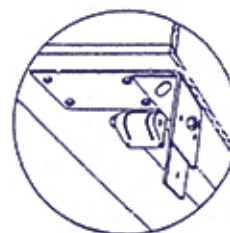

FIG. A



For Safety's sake:  
This is the proper way to store the jack when not in use.

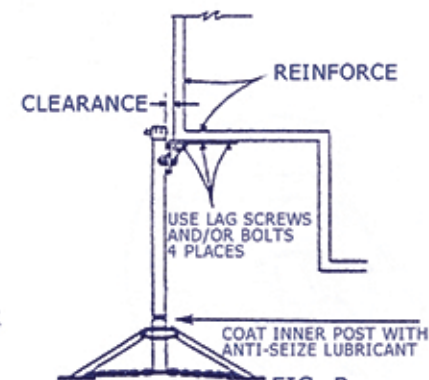
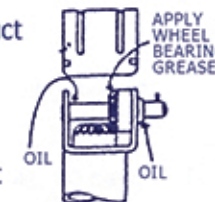

FIG. B

## MAINTENANCE

1. Lubricate jack at least every six months in the following manner:

- A. Extend jack as far as possible
- B. Lubricate entire outer length on inner tube with SAE 30 heavy oil or an anti-seize product
- C. Squirt oil in oil hole at top of outer tube
- D. Clean dirt, mud, tar, etc. from jack



2. Titan's three guide bearings and one master thrust bearing are permanently lubricated. However about once a year remove gear cover and lubricate gears with light grease and apply a few drops of oil to the bearings.
3. Apply a good auto wax to the outer surfaces of the jacks to maintain an attractive appearance. In coastal, rainy or humid areas, we recommend that a liquid wax such as Mother's Polish or Turtle Wax be applied to the entire surface of the jacks. Keep the wax intact with a spray wax periodically. An excellent alternate is Mercury's Corrosion Guard. Repeat each year.